

# IMPORTANT! Updated *Smart Menu* and *QuikRuler* Installation Instructions

Connecting the  
**Smart Menu**  
to a Roll-Up II with  
Firmware Version **J3.x** or Later  
(See label on back of tablet)

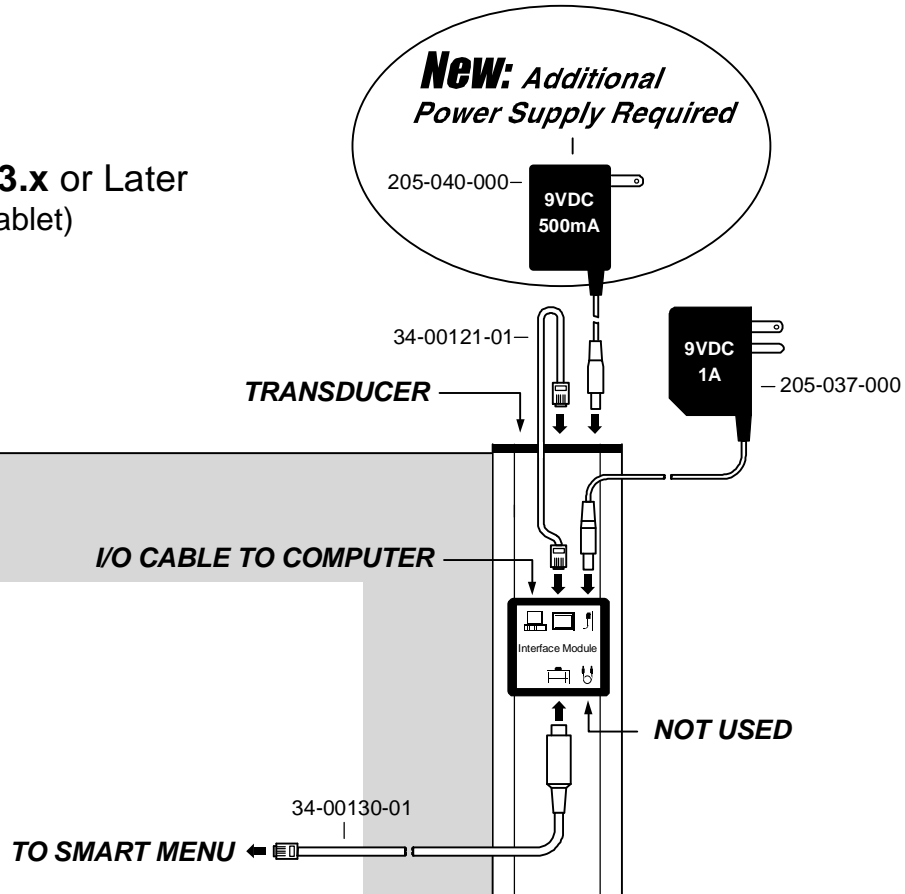

Connecting the  
**QuikRuler**  
to a Roll-Up II with  
Firmware Version **J3.x** or Later  
(See label on back of tablet)

